

SOFINO 90/200

R

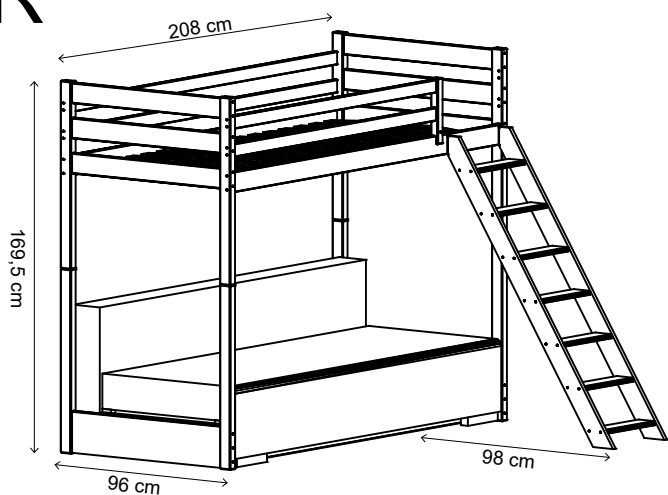

L

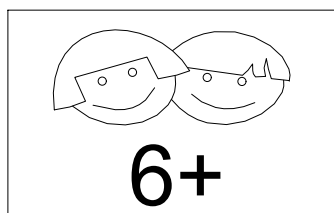
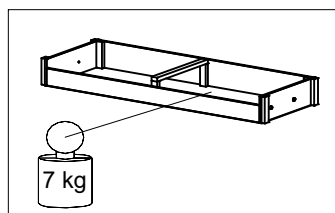
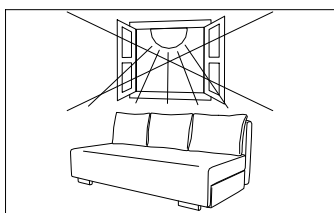
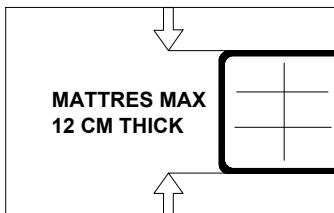
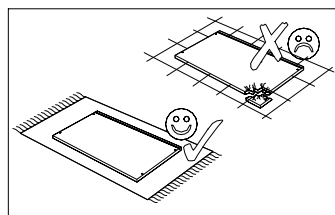
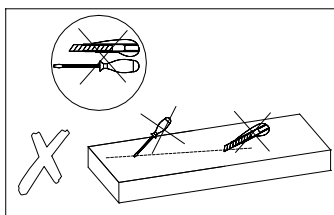
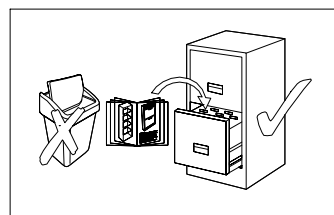
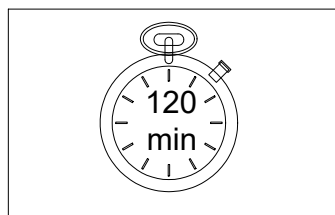
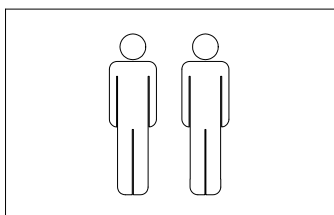
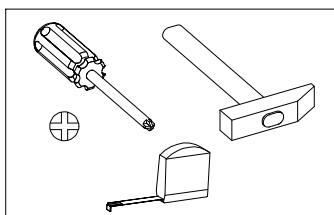
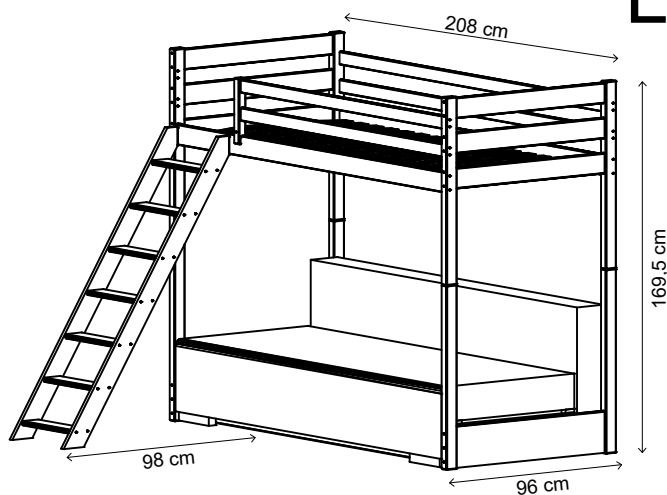

No.	Size	Pcs.	Package
1.1	840x60	4	1/3
1.2	855x60	4	1/3
2.1	840x200	2	1/3
3.1	840x95	6	1/3
3	2000x95	2	2/3
4	2000x62	2	2/3
5	1515x90	1	2/3
6	300x40	2	2/3
7	1640x95	2	2/3
8	365x95	7	2/3
9	995x25	4	2/3
10	895x53	1	1/3
11	2000x600	1	3/3
12	2000x800	1	3/3
13	600x400	3	3/3
14	225x40	2	3/3

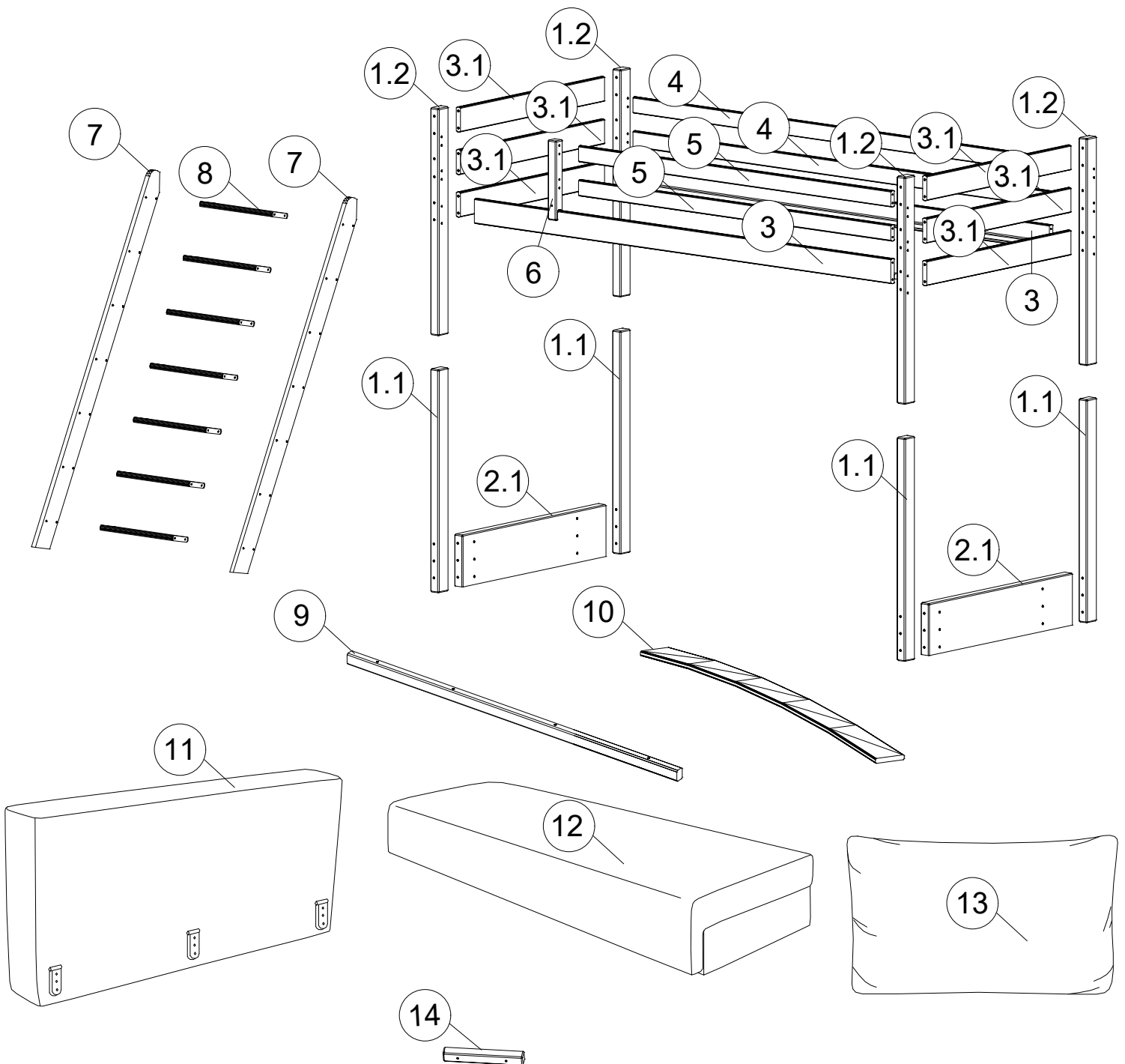

1

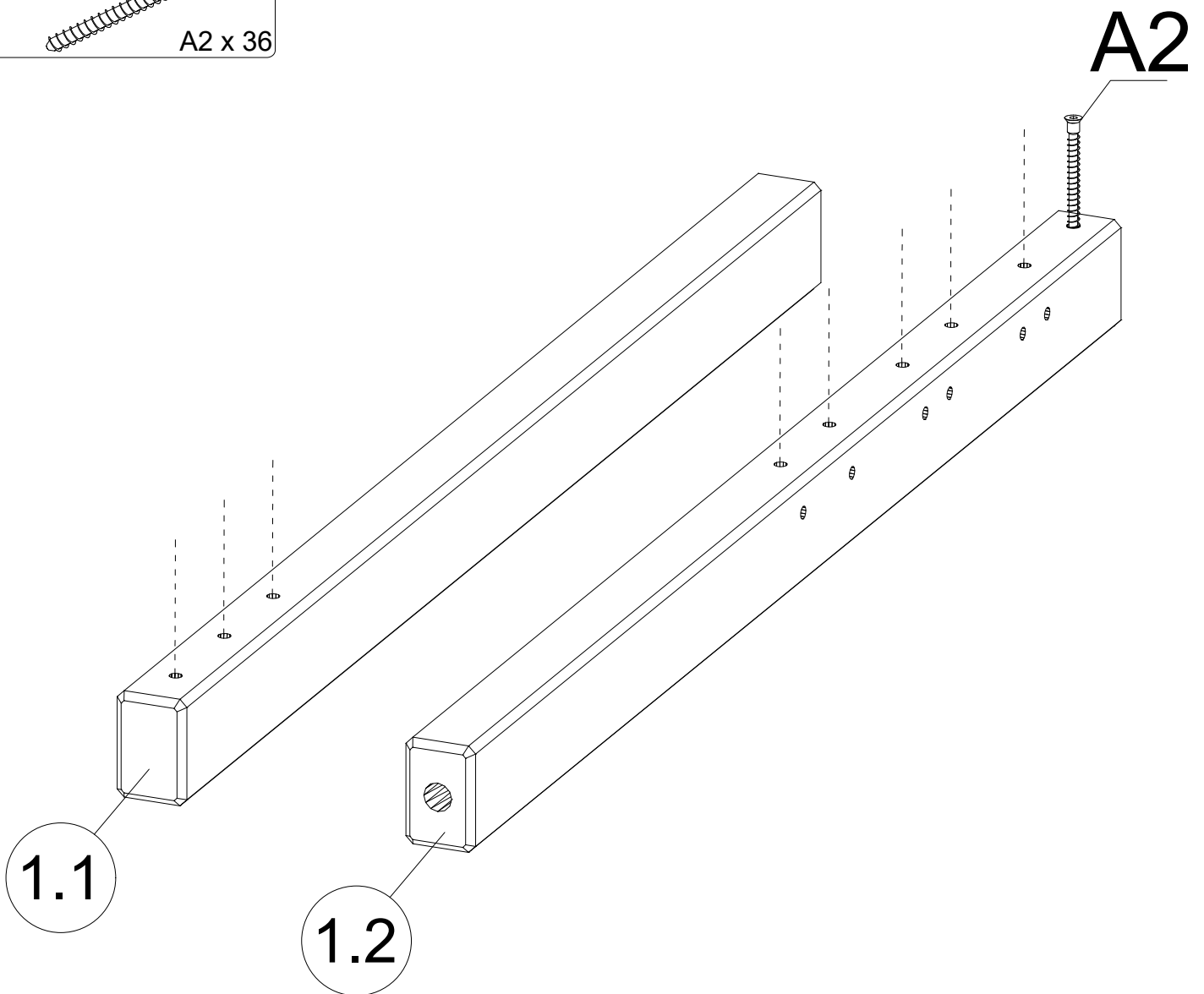
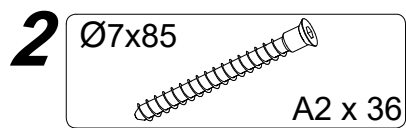
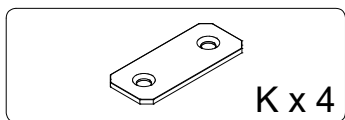
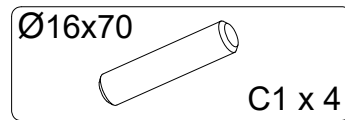
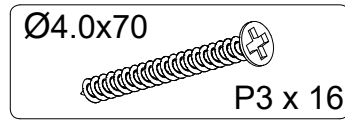
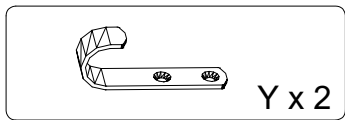
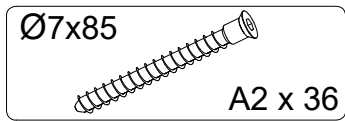
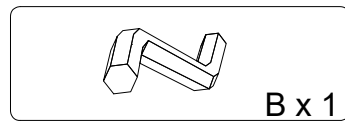
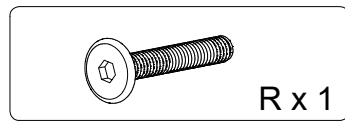
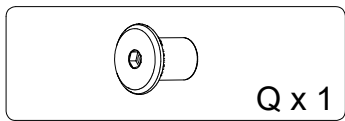
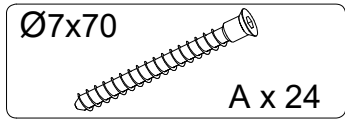
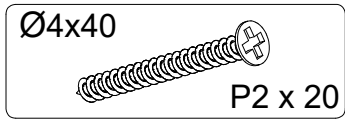
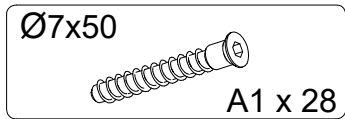
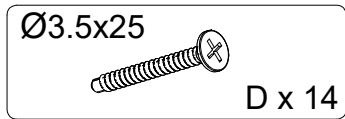

3

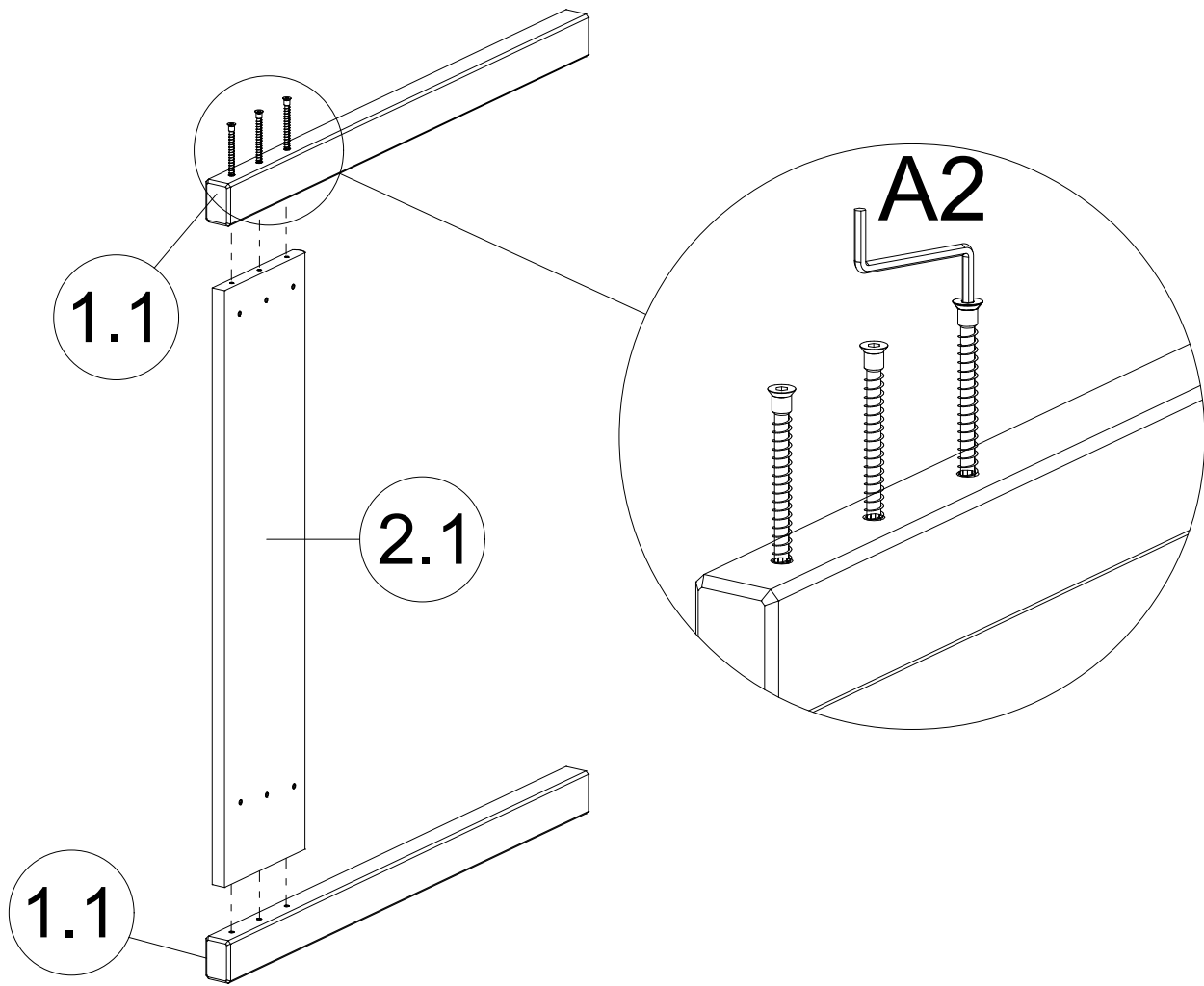

4

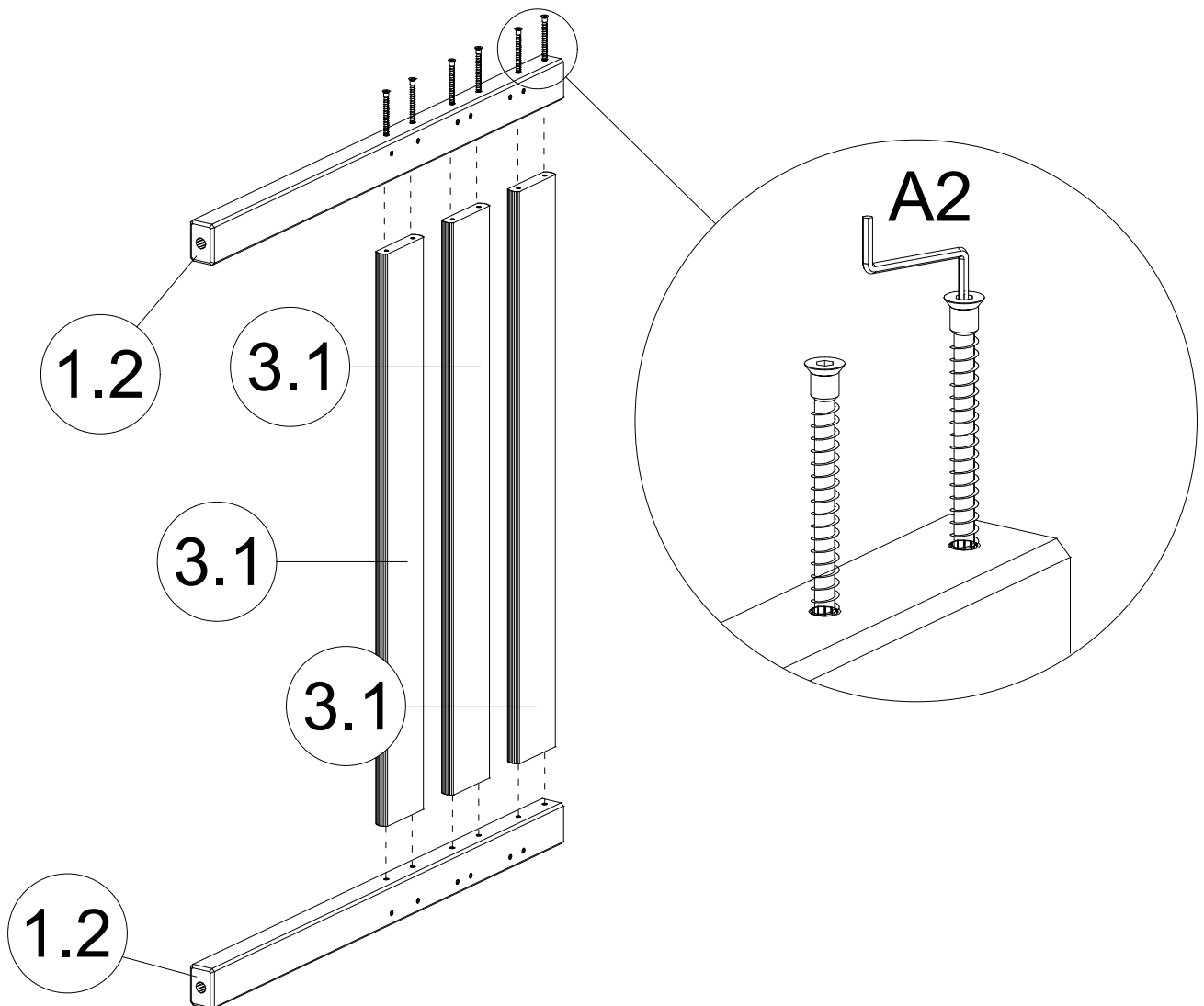

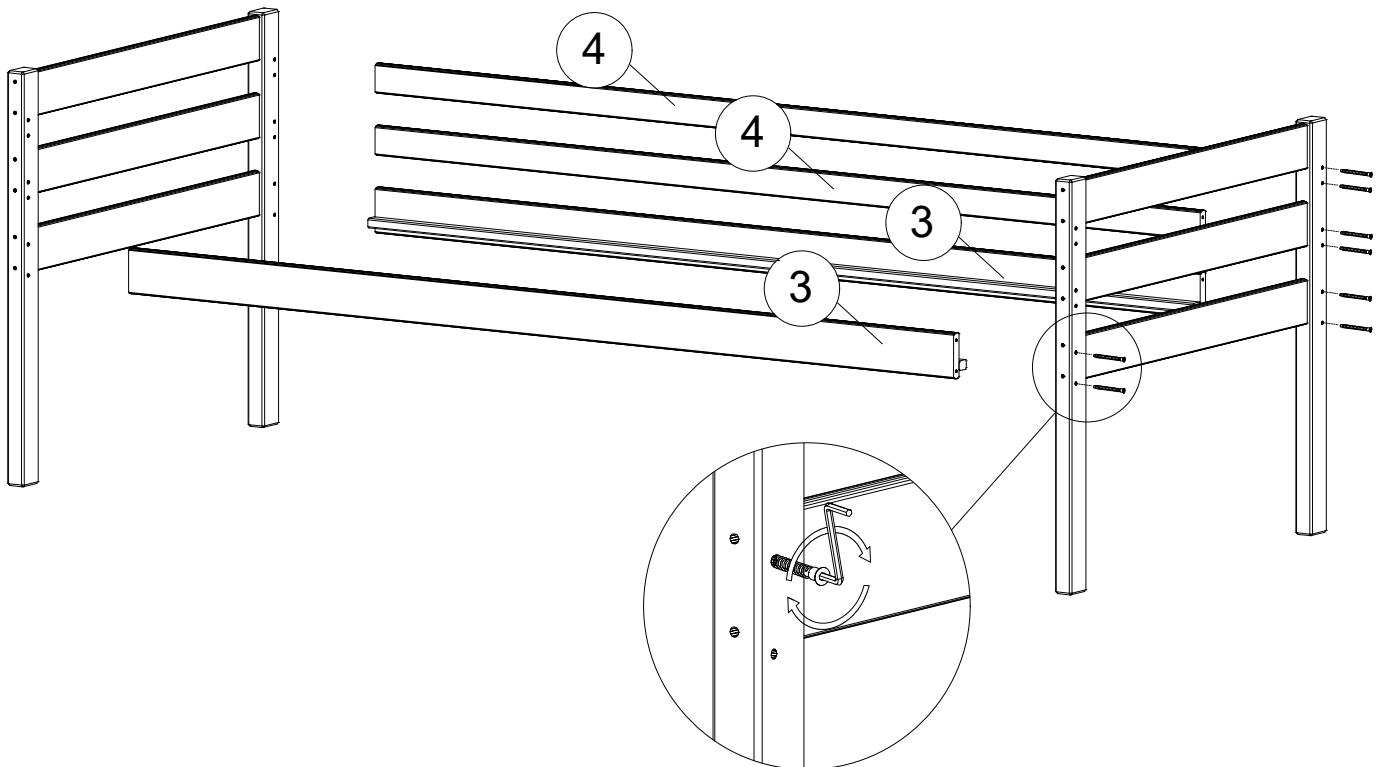
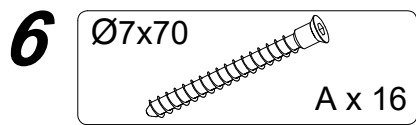
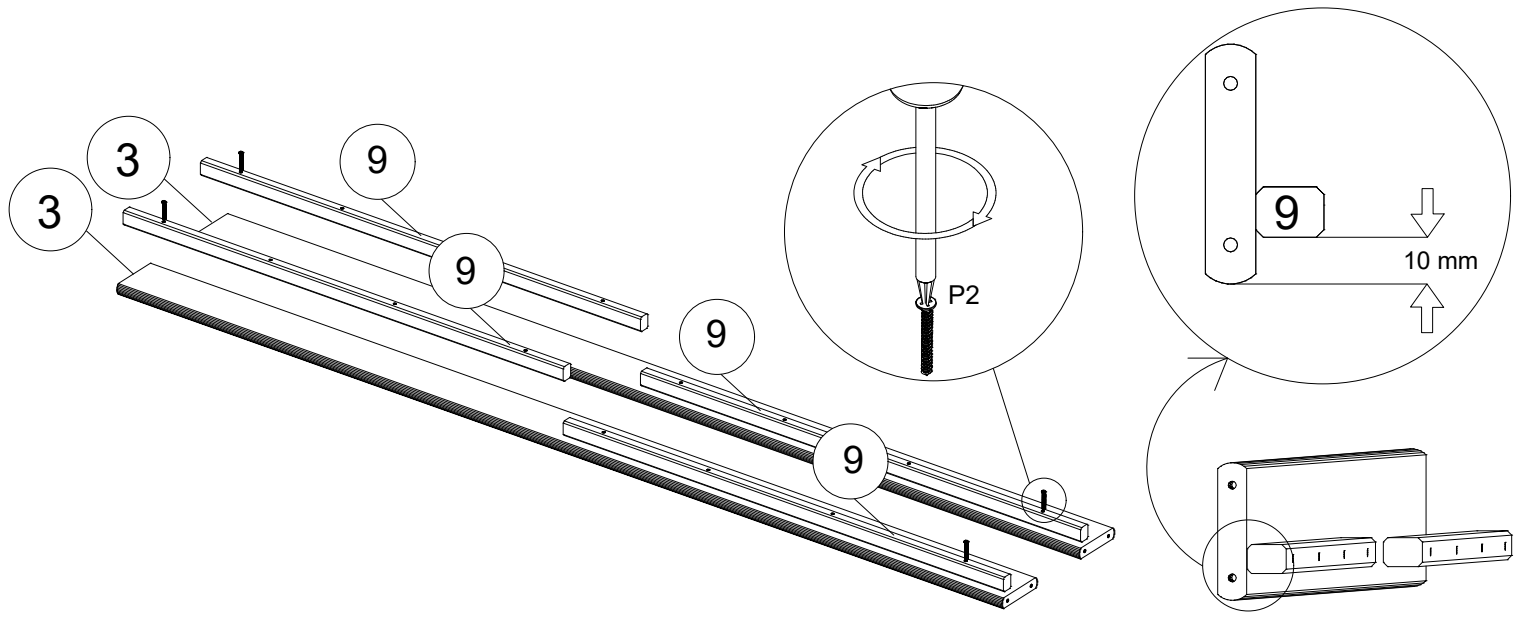
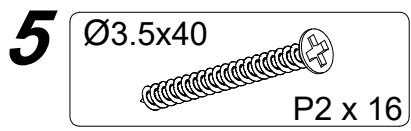

7

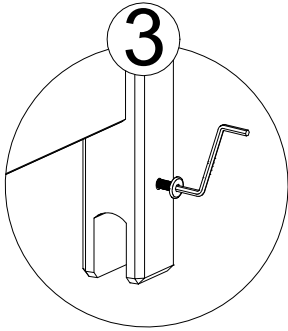
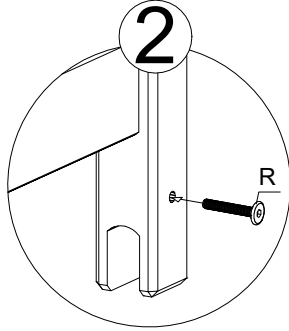
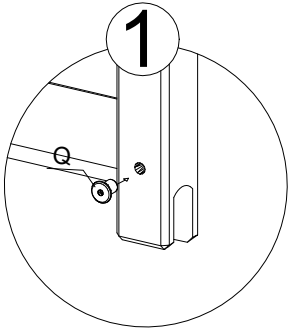
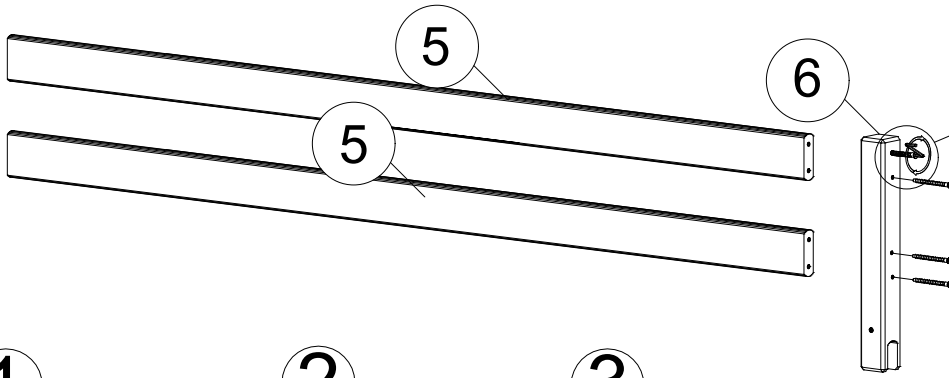
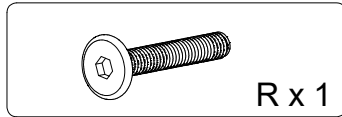
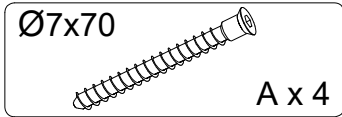
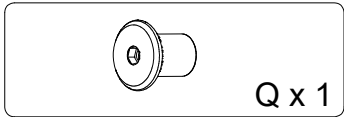

8

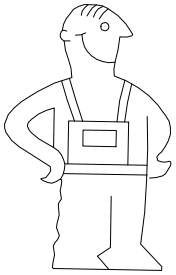

L

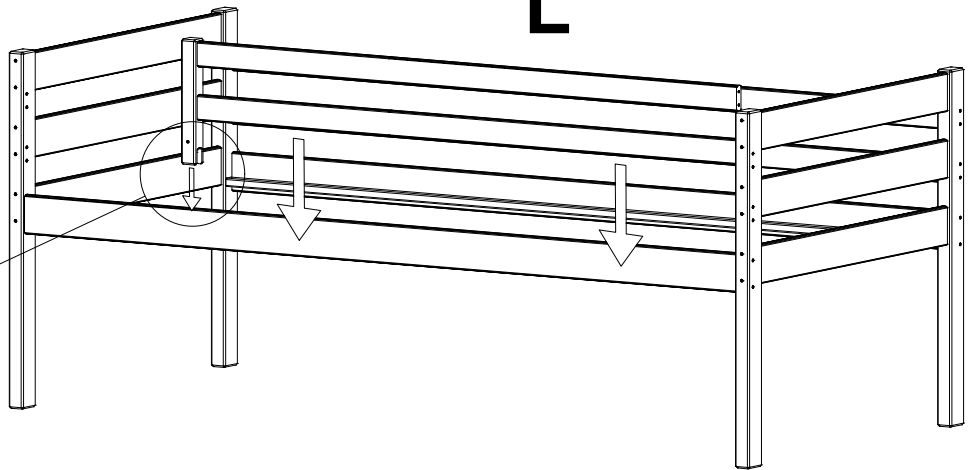
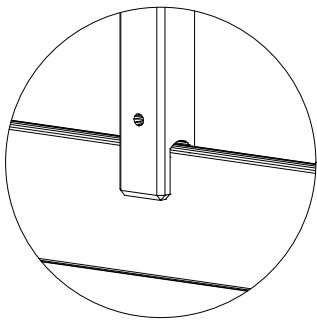

R

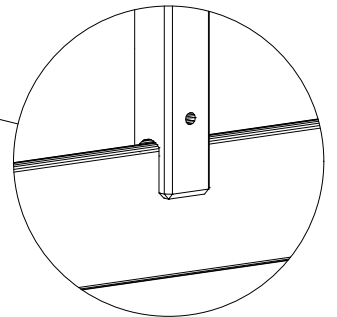
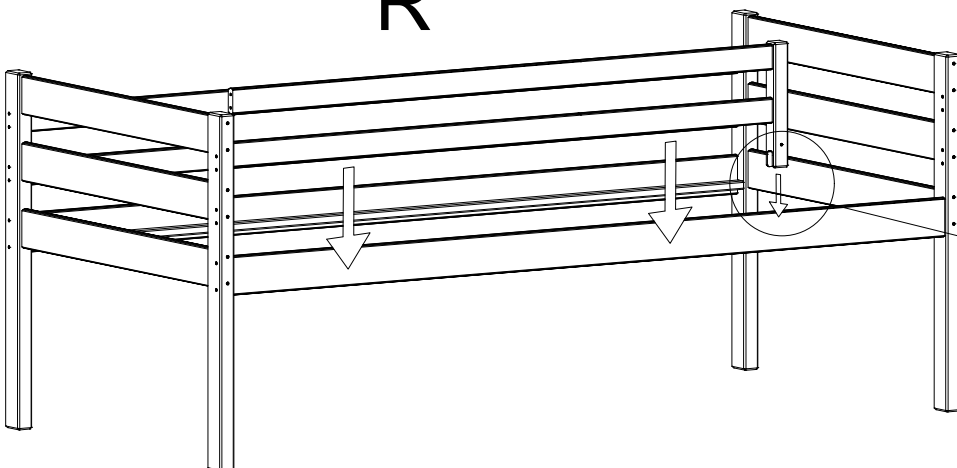

9

Ø7x70

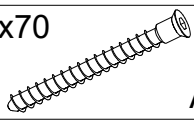

A x 4

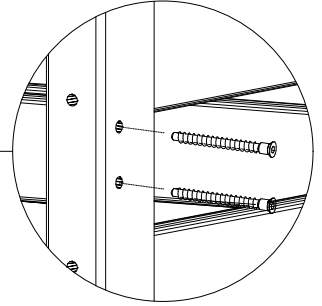
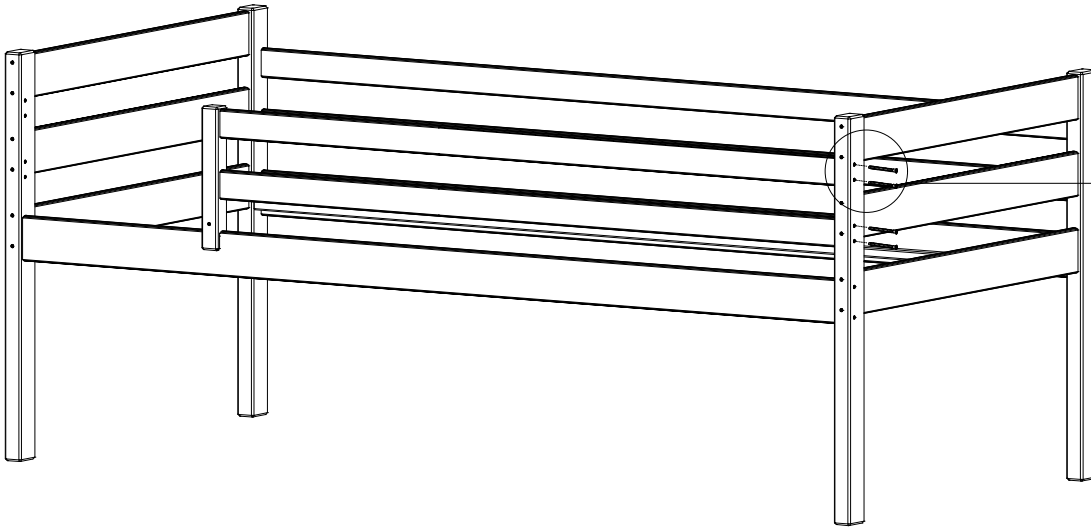

10

Ø7x50

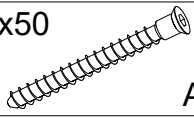

A x 28

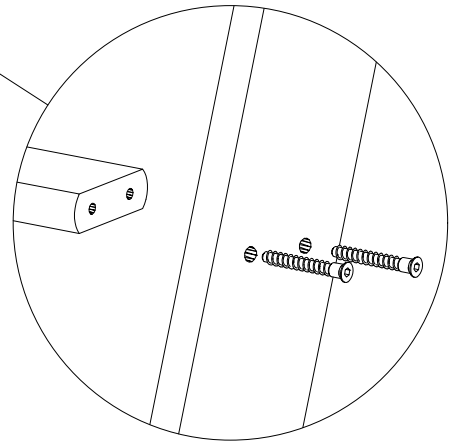
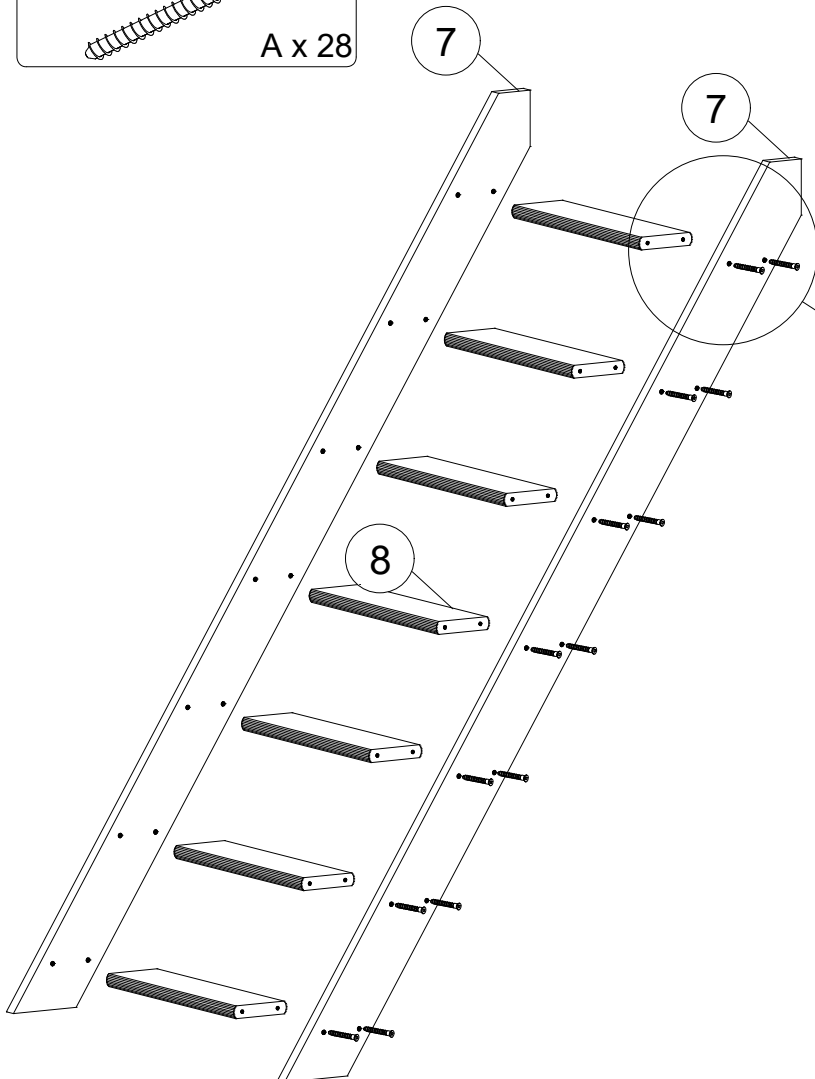

11

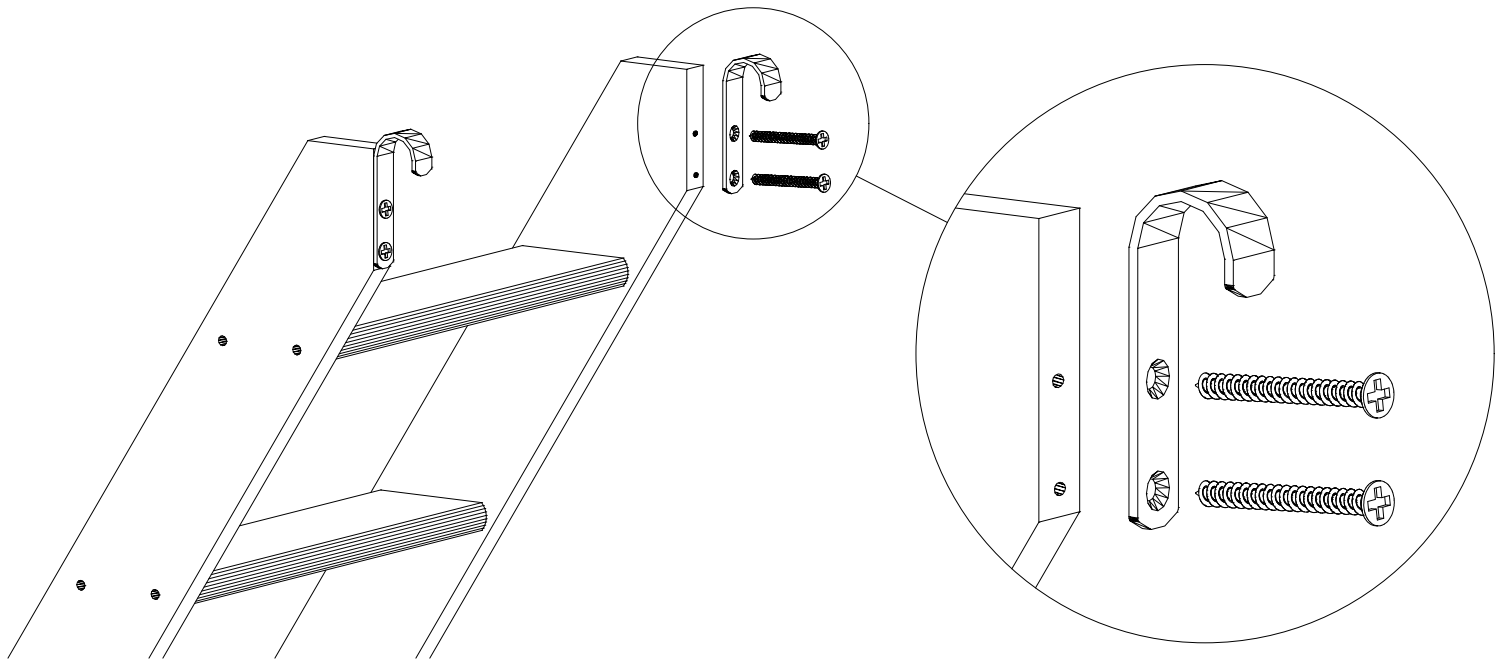
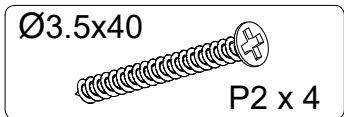
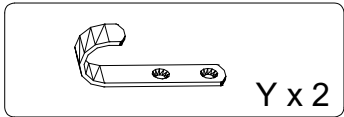

12

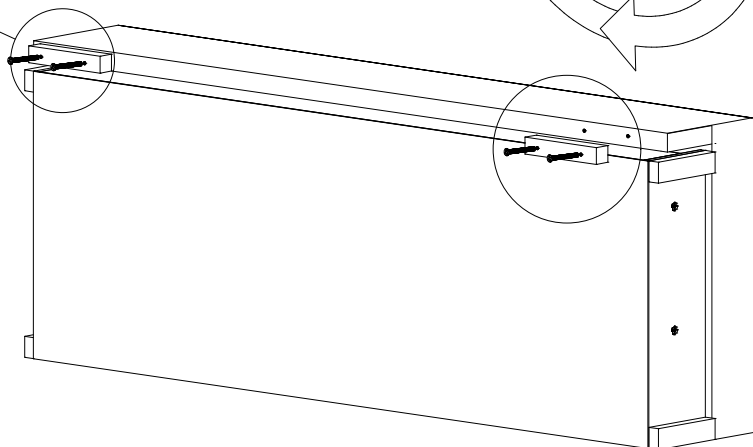
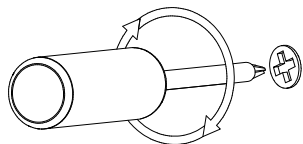
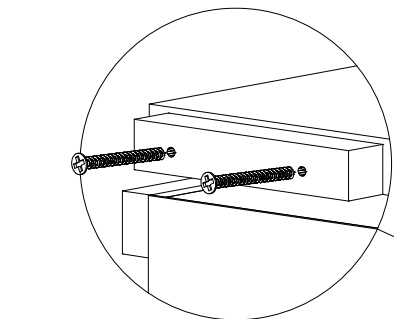
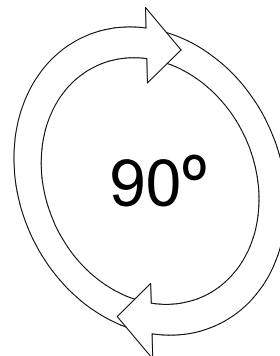
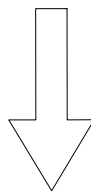
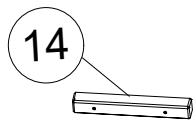
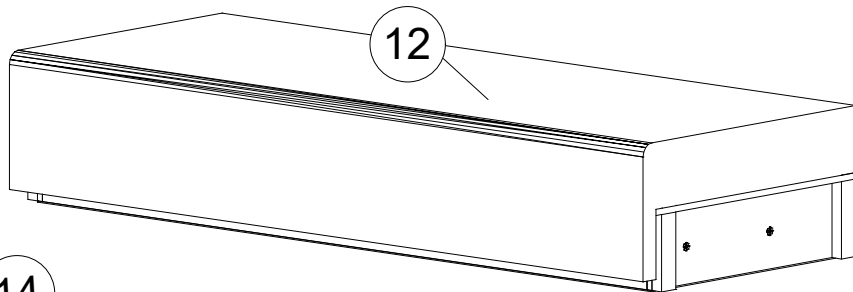
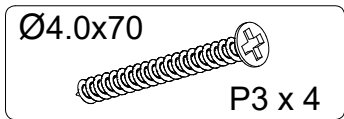

13

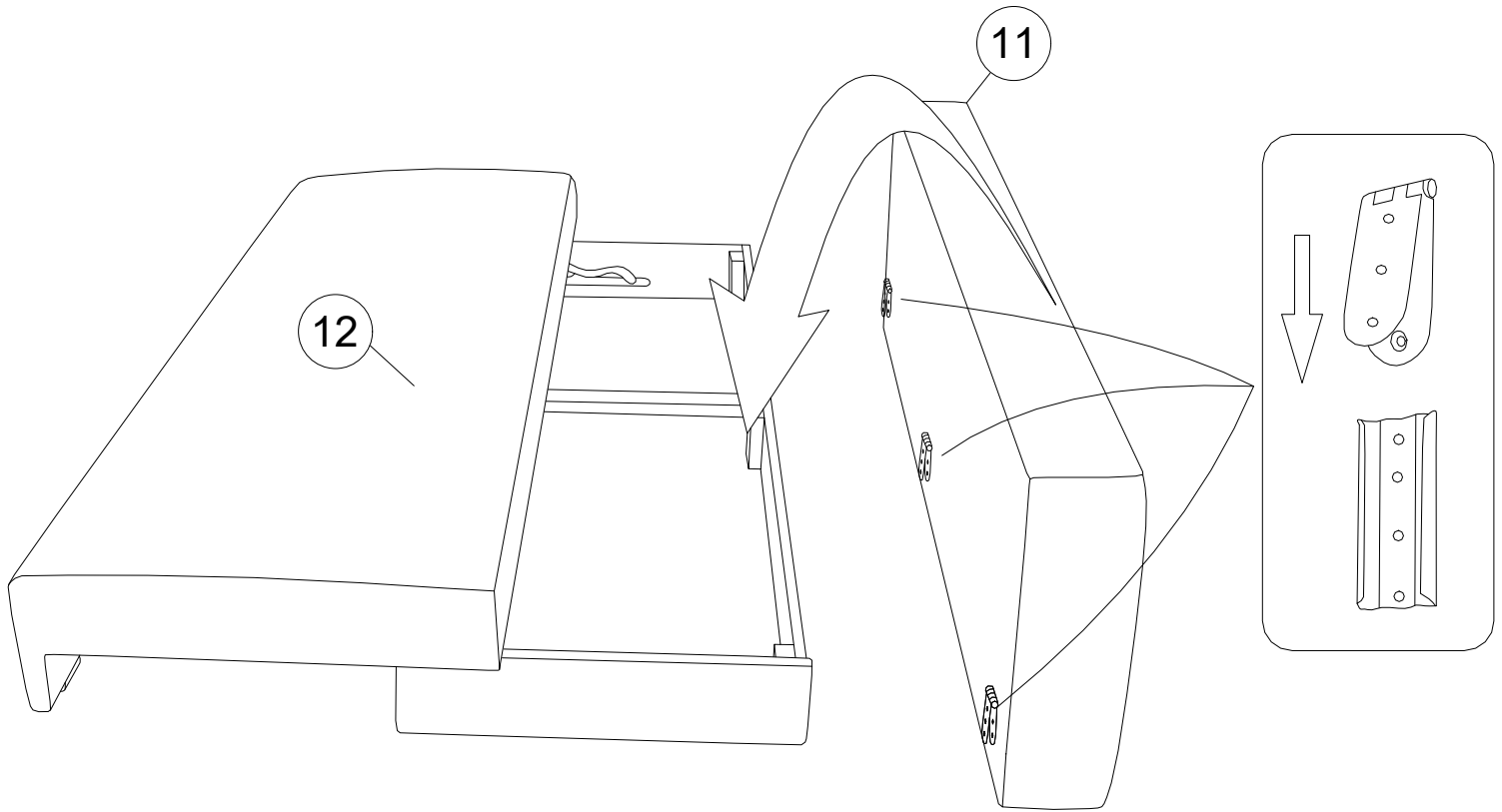

14

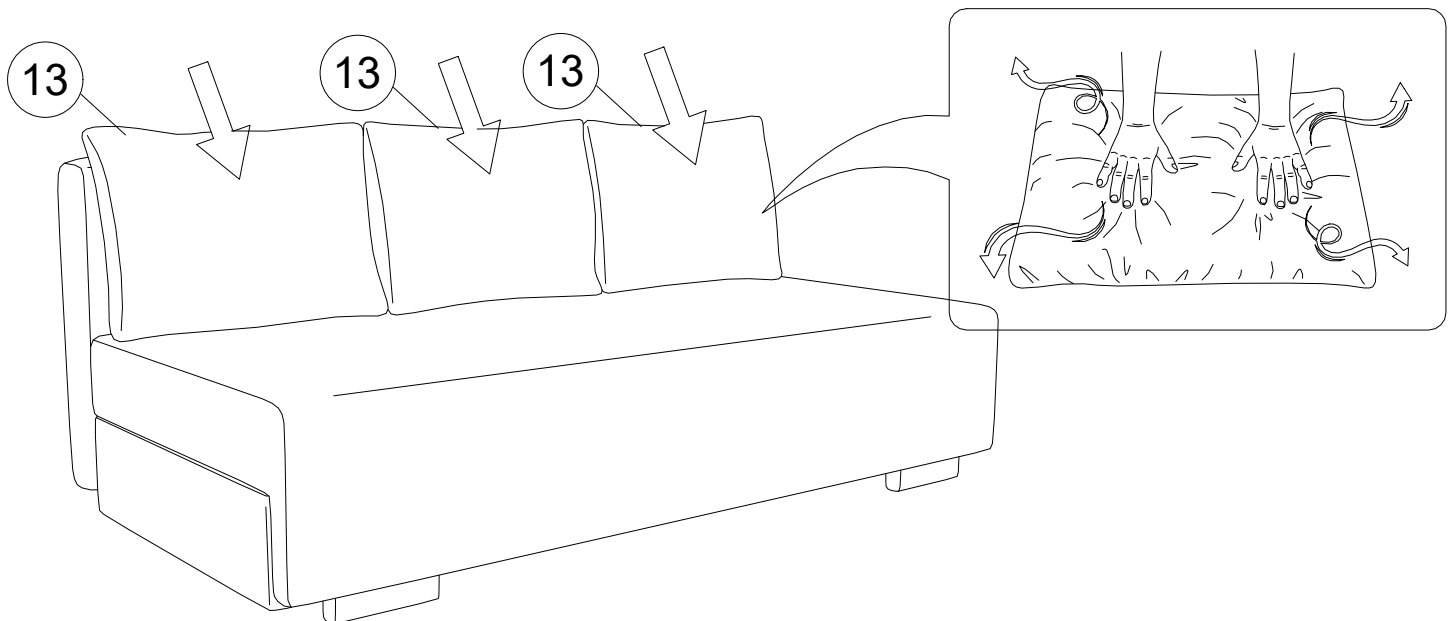

15

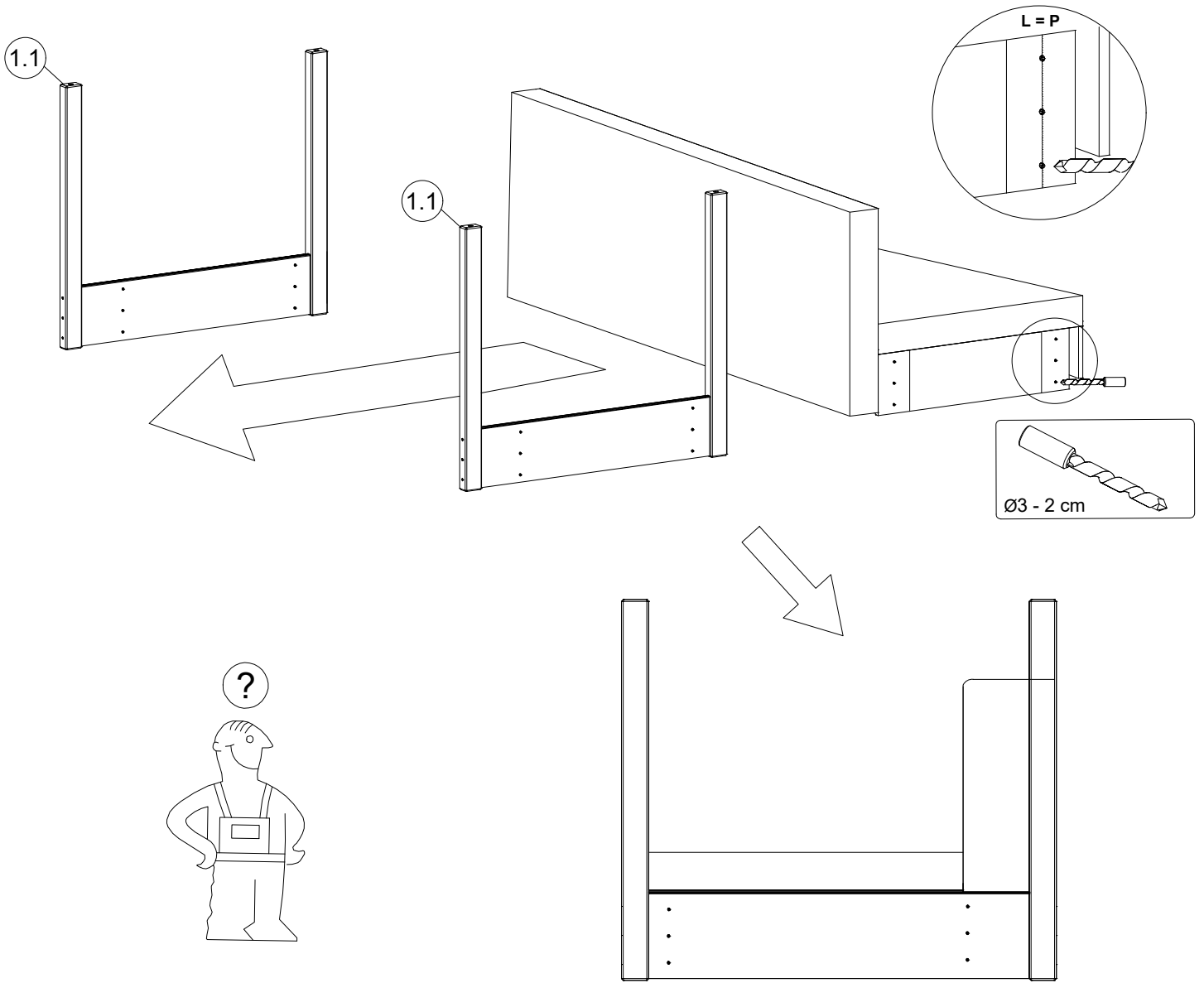

16

$\text{Ø}4.0 \times 70$

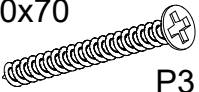

P3 x 12

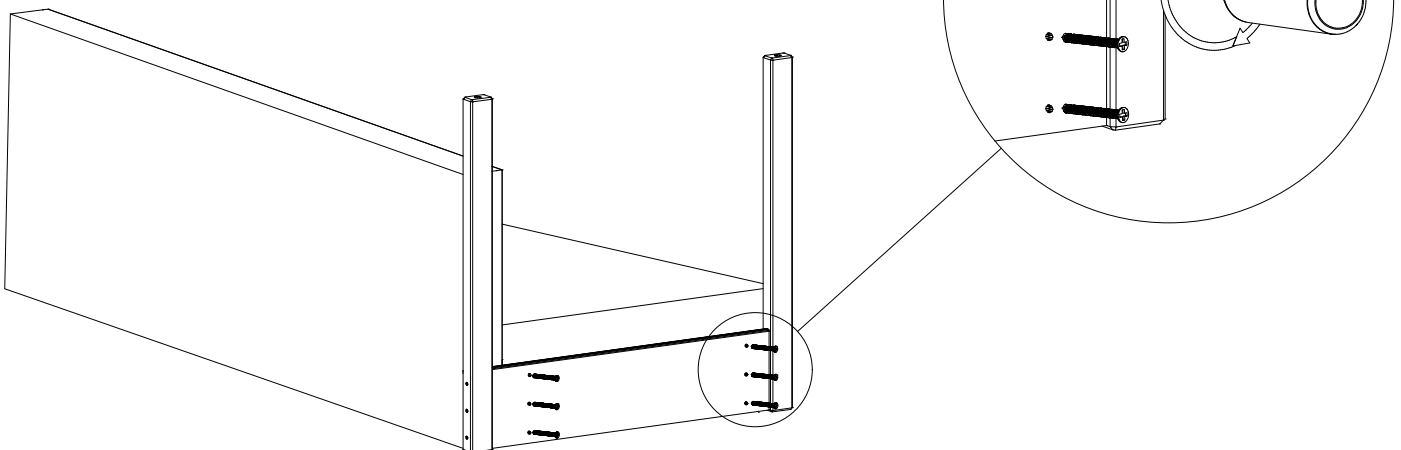

17 Ø16x70

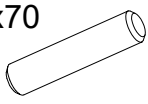

C1 x 4

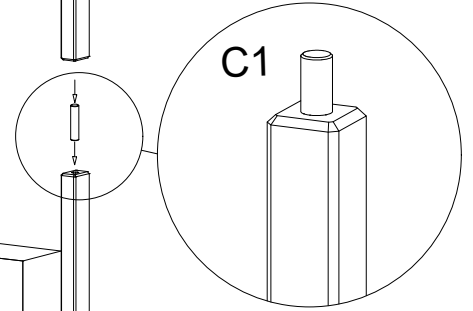
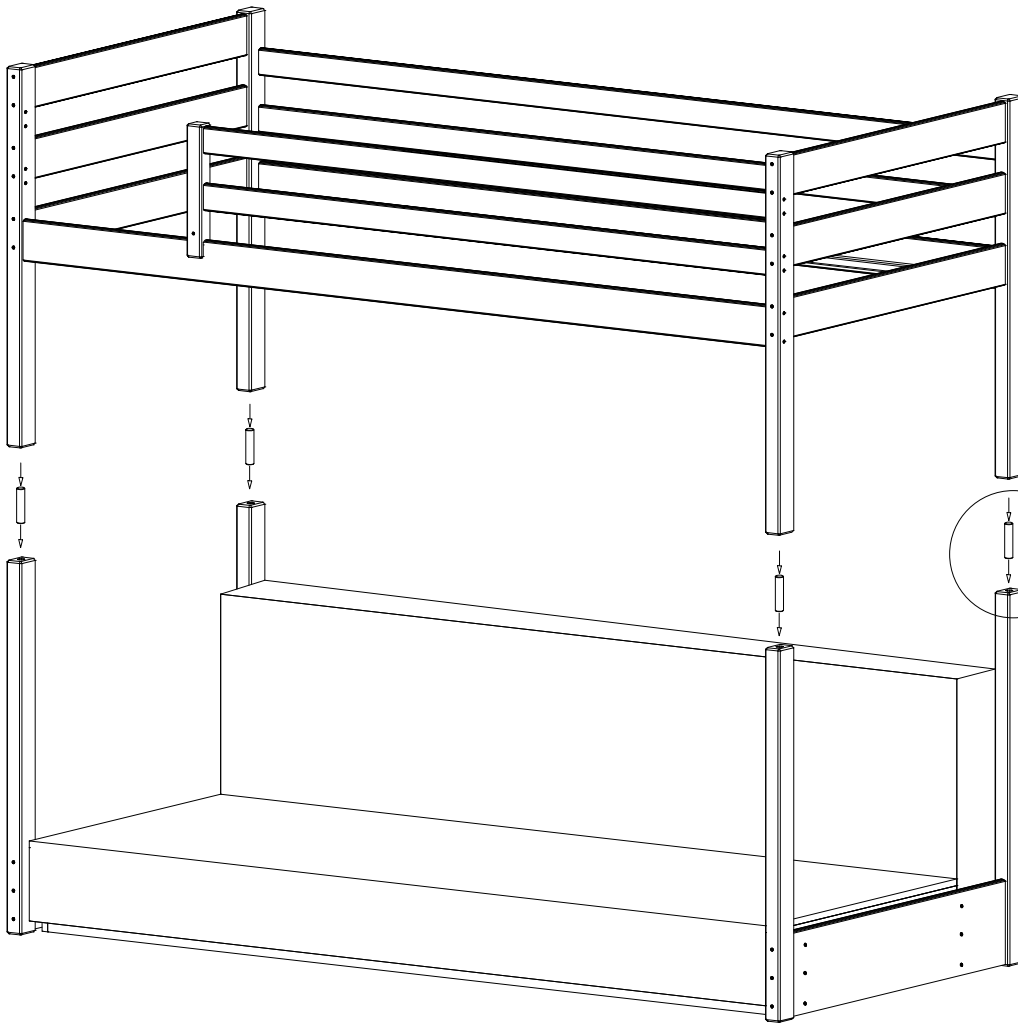

18

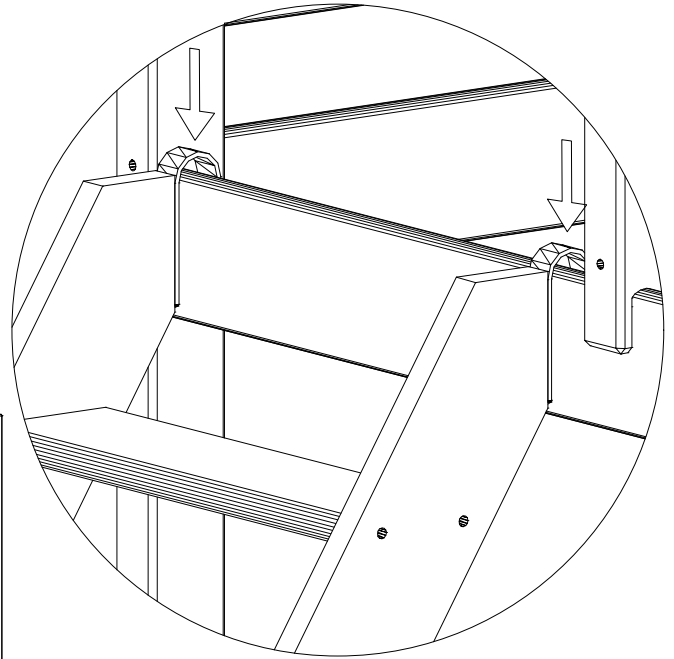
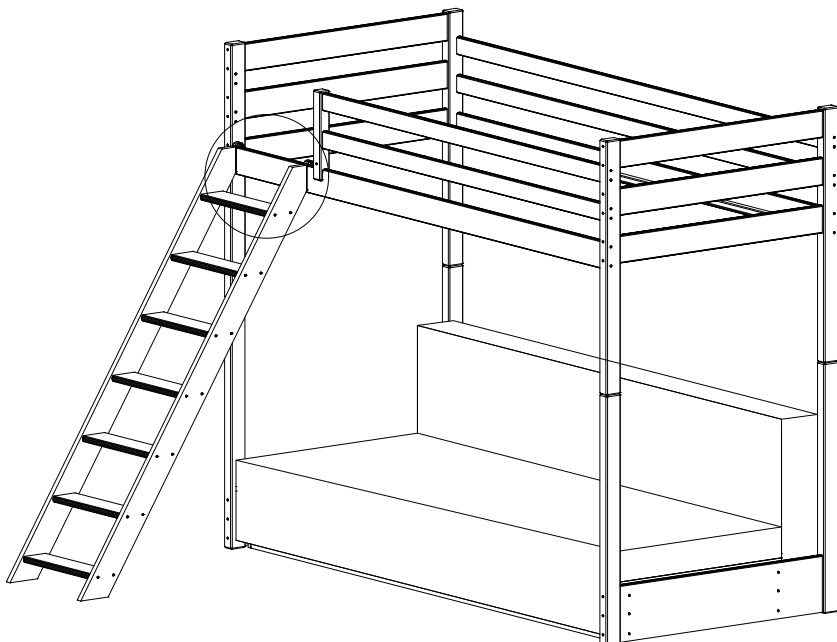

19

Ø3.5x25
D x 6

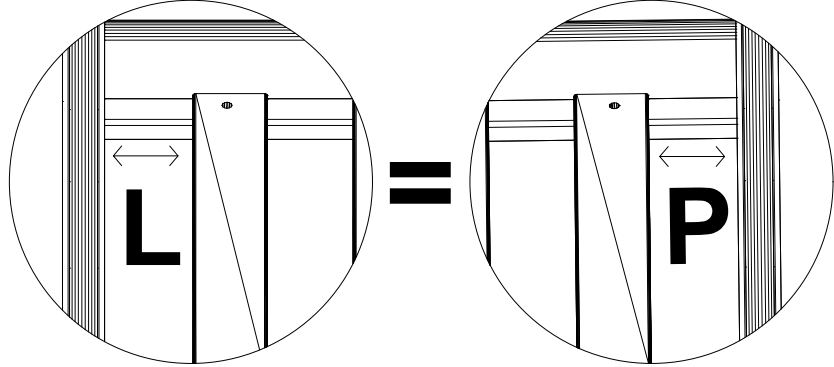
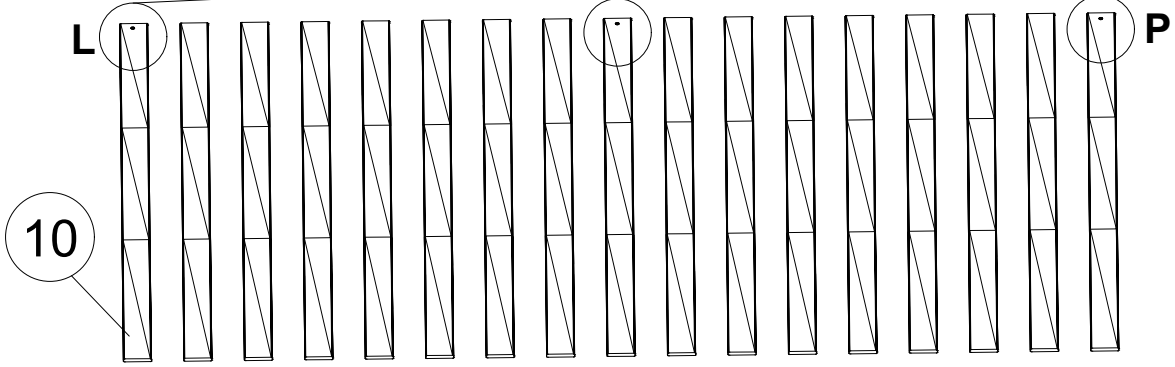
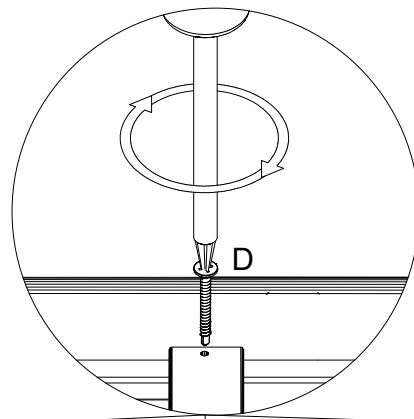

20

K x 4

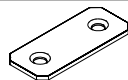

Ø3.5x25
D x 8

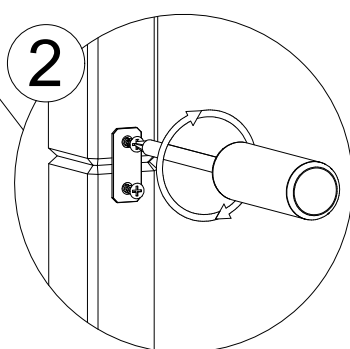
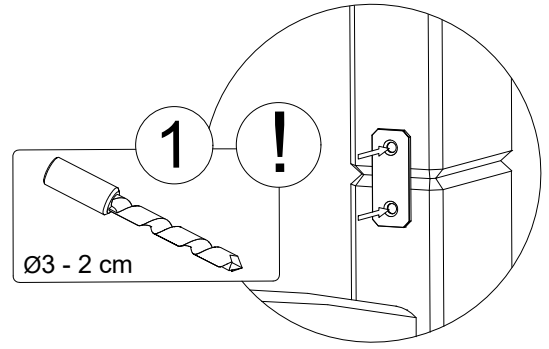
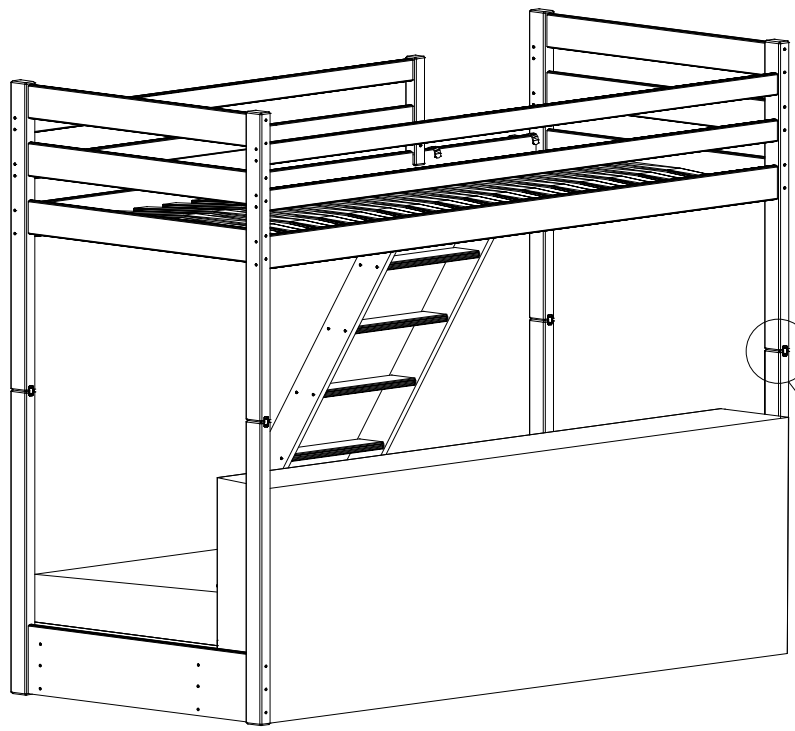

PL - Instrukcja obsługi

WAŻNE - PRZECZYTAJ UWAŻNIE - ZACHOWAJ DO PÓŹNIEJSZEGO WGLĄDU

- OSTRZEŻENIE Łóżka piętrowe pojedyncze oraz łóżko górne w łózkach piętrowych nie nadają się dla dzieci poniżej szóstego roku życia ze względu na niebezpieczeństwo obrażeń ciała związanych z upadkiem,
- OSTRZEŻENIE W przypadku nieprawidłowego używania łózek piętrowych podwójnych i pojedynczych, mogą one stwarzać poważne niebezpieczeństwo obrażeń ciała związanych z uwięzieniem. Nigdy nie należy przyczepiać, ani zawieszać elementów do części górnego łóżka, które nie są przystosowane do właśnie takiego użycia. Elementy te to, nie ograniczając się do wymienionych, linki, wstążki, sznurki, haczyki, paski i torby,
- OSTRZEŻENIE Dzieci mogą zaklinować się między łóżkiem i ścianą, pochylona częścią dachu, sufitem, przyległymi meblami (na przykład szafa) lub innym elementem konstrukcji. Aby uniknąć poważnych obrażeń ciała, odległość pomiędzy górną barierką zabezpieczającą, a elementem sąsiadującym, nie może przekraczać 75 mm, lub musi być większa niż 230 mm,
- OSTRZEŻENIE Nie używać górnego łóżka lub pojedynczego łóżka piętrowego, jeżeli brakuje jednego z elementów konstrukcyjnych lub jest on zniszczony. Części zamienne należy zamawiać u producenta lub w sklepie.
- Zalecany rozmiar materaca pasującego do tego łóżka to 2000 mm x 900 mm x 120 mm.
- Należy wietrzyć pomieszczenie, aby utrzymać wilgotność powietrza na średnim poziomie i uniknąć rozwoju pleśni w łóżku i w jego okolicy
- Elementy montażowe muszą być odpowiednio dokręcone i systematycznie sprawdzane. Dokręcać w razie potrzeby
- Zgodnie z europejskimi wymogami bezpieczeństwa normy PN-EN 747-1+A1:2015-08
- UWAGA! Produkt może wydzielać zapach po złożeniu, do 72 godzin
- Nie używaj innych narzędzi niż zalecane
- Pozostawienie włączonej lampki nocnej może zwiększyć bezpieczeństwo dziecka śpiącego na górnym łóżku

EN - User manual

IMPORTANT - READ CAREFULLY - KEEP FOR LATER REFERENCE

- WARNING Single bunk beds and the upper bed in bunk beds are not suitable for children under the age of six due to the risk of injury from falling,
- WARNING If double and single bunk beds are used incorrectly, they can they pose a serious risk of bodily injury associated with entrapment. You should never attach or attach items to parts of the upper bed that are not designed for such use. Elements including, but not limited to, ropes, ribbons, strings, hooks, belts and bags,
- WARNING Children can become trapped between the bed and the wall, sloping roof, ceiling, adjacent furniture (for example, a wardrobe) or other structural element. To avoid serious personal injury, the distance between the upper safety rail and the adjacent element must not exceed 75 mm, or must be greater than 230 mm,
- WARNING Do not use the upper bunk or single bunk bed if one of the structural components is missing or damaged. Spare parts must be ordered from the manufacturer or from the store.
- The recommended mattress size for this bed is 2000mm x 900mm x 120mm.
- Ventilate the room to keep air humidity at a medium level and to avoid mold growth in and around the bed
- Mounting elements must be properly tightened and checked regularly. Tighten if necessary
- In accordance with European safety requirements of the PN-EN 747-1+A1:2015-08 standard
- ATTENTION! The product may emit an odor after being deposited, up to 72 hours
- Do not use tools other than those recommended
- Leaving the bedside lamp increase the safety of a child sleeping on the upper bed

DE - Gebrauchsanweisung

WICHTIG - AUFMERKSAM LESEN - ZUR SPÄTEREN EINSICHTNAHME AUFZUBEWAHREN

- WARNUNG Hochbetten und das obere Bett bei Etagenbetten sind wegen des Verletzungsrisikos durch Stürze nicht für Kinder unter sechs Jahren geeignet.
- WARNUNG Wenn sie nicht richtig verwendet werden, können Hochbetten und Etagenbetten ein schweres Verletzungsrisiko durch strangulierung darstellen. Es dürfen niemals Elemente an Teilen des Hochbetts befestigt oder aufgehängt werden, die nicht zur Verwendung mit besagtem Bett bestimmt sind. Diese Elemente umfassen, sind aber nicht beschränkt auf, Seile, Fäden, Schnüre, Haken, Gürtel und Taschen.
- WARNUNG Kinder können sich zwischen dem Bett und einer Wand, einer gekippten Wandstelle, der Decke, Möbeln in der Nähe (zum Beispiel Schränke) oder anderem einklemmen. Um jedes Risiko einer schweren Verletzung zu vermeiden, darf der Abstand zwischen der oberen Sicherheitsschranke und den Elementen in der Umgebung 75 mm nicht überschreiten oder muss größer als 230 mm sein.
- WARNUNG Das Hochbett oder das Etagenbett darf nicht verwendet werden, wenn ein Teil des Aufbaus fehlt oder beschädigt ist. Ersatzteile müssen beim Hersteller oder im Laden bestellt werden.
- Die Montage- und Gebrauchsanweisungen des Herstellers müssen unbedingt immer befolgt werden.
- Die empfohlene Größe der mit dem Bett zu verwendenden Matratze beträgt 2000 mm x 900 mm x 120 mm
- WARNUNG DIE OBERSEITE DER MATRATZE DARF NICHT ÜBER DIE AM BETT VORHANDENE MARKIERUNG ÜBERSTEHEN
- Es ist notwendig, den Raum zu lüften, um einen geringen Feuchtigkeitsgrad aufrechtzuerhalten und die Entwicklung von Schimmel im Bett und seiner Umgebung zu verhindern.
- Die Montagevorrichtungen müssen immer angemessen festgezogen und regelmäßig überprüft werden. Wenn nötig, erneut festziehen.
- Entspricht den europäischen Sicherheitsanforderungen der Norm DIN EN 747+A1: 2015.
- Wenn ein Nachtlicht vorhanden ist, kann dies dem im oberen Bett schlafenden Kind mehr Sicherheit geben