

Assembly Instructions



15 min



(A) X1

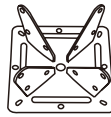

(B) X1



(C) X4



M6X12MM
(D) X4



M6X25MM
(E) X12



M6X20MM
(F) X12



(G) X16



(H) X12



M5
(I) X1



M4
(J) X2

Step 1

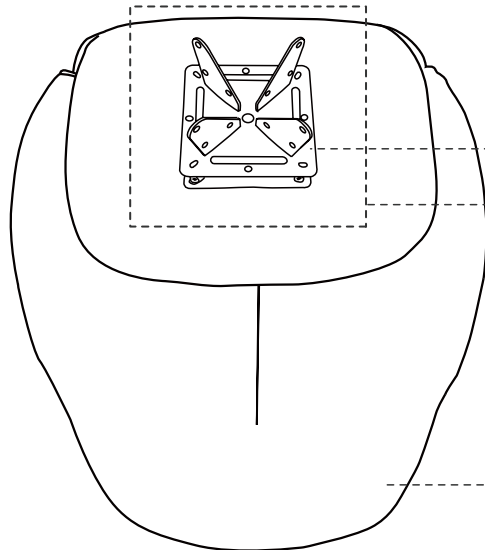

(I) X1

100%

(D) X4

(G) X4

(B) X1

(A) X1

Step 2

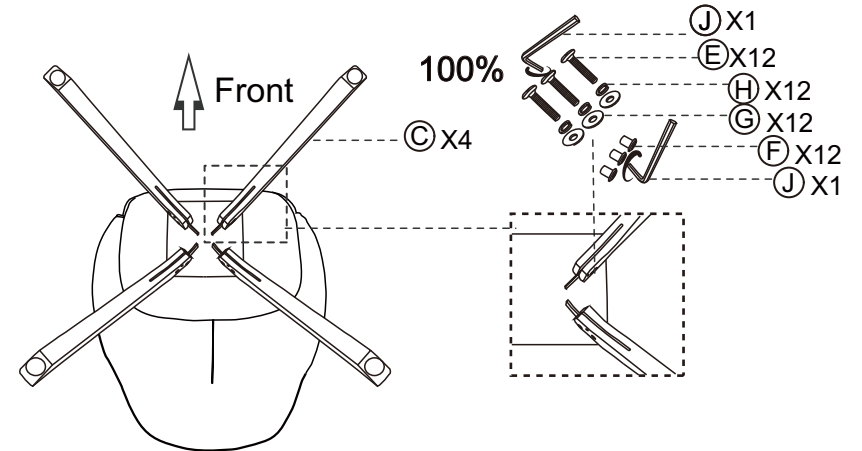

Step 3

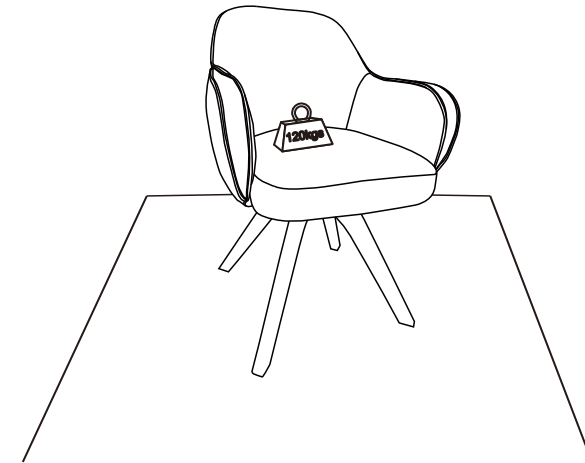

- (D) Bitte überprüfen Sie in regelmäßigen Abständen den festen Sitz der Schrauben!
- (GB) Please check the screws for tightness at regular intervals!
- (F) Veuillez contrôler régulièrement que les vis sont convenablement serrées !
- (ES) ¡Compruebe periódicamente que los tornillos estén bien apretados!
- (IT) Controllare regolarmente che le viti siano ben strette!
- (PL) Należy regularnie sprawdzać dokręcenie śrub!
- (NL) Controleer op regelmatige afstanden of de schroeven goed vast zitten!
- (SWE) Kontrollera med jämna mellanrum att skruvarna sitter fast ordentligt!
- (SK) V pravidelných intervaloch kontrolujte pevné dotiahnutie skrutiek!
- (SL) Redno preverjajte, ali so vijaki trdno priviti!
- (HR) Redovito provjeravajte čvrsto nalijeganje vijaka!

